

Long Series Power Collet Chuck for Bar Machining

Long Body/Wide Range

High accuracy spring collets require a longer body design but Klamp collet chuck design ensures that all external dimensions have been optimised to provide maximum tool clearance. Gripping capacities of the series range from 1.6mm to 80mm

High Speed

Direct mount design ensures high concentricity suitable for higher speed operations.

First & Second Operation Collet Chuck

Klamp CRL collet chucks are suitable for spring, varibore and rubberflex collets increasing its flexibility. Varibore and rubberflex collets allow rough, unfinished bar to be machined in the first operation and spring collets can be used for high accuracy in the second operation.

Fixed Length Collet

Workpiece remains in a fixed position during actuation allowing for precise z-axis positioning. A tapered sleeve is pushed forward, compressing the collet and gripping the workpiece.

Problem Free Installation

Klamp collet chucks are provided with mounting bolts and an optional custom machined drawtube connector allowing you to start using the Klamp collet chuck straight out of the box.

Adjustable Collets Mounted Workstop for Spring Collets



- Easy to use, installation time – less than one minute
- Available for D173E (Part No: **WS-D173E**) and D185E (Part No: **WS-D185E**) spring collet types
- Suitable for round, square and hexagon spring collets
- No deformation of collet shank
- No influence on clamping characteristics of collet or collet chuck

3 Different Collet Types Available



Spring Collets*

Suited for second operation work, collets are size matched according to gripped diameters, enabling you to have a high gripping accuracy. Collets can be supplied as smooth or serrated as required.



Varibore Collets**

Ideal for first operation work as they have a 2-3mm gripping range enabling you to handle rough bar. Supplied either as smooth, serrated or super grip.

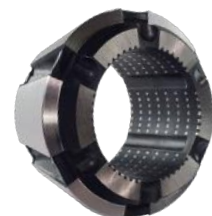

Rubberflex Collets***

The same accuracy specification as spring collets. Elastic rubber-metal vulcanization allows a clamping range of +/- 1mm to the nominal diameter.



Quick & Easy Mounting

Klamp collet chucks mount directly to the lathe spindle or use a precision adaptor plate to ensure a consistent mounting without the need for correction. The precision fit of the Klamp collet chuck enhances the rigidity of the overall system. The need for adjustment is minimal, meaning less machine downtime.

Long service life

All Klamp collet chucks are case hardened, optimising the rigidity, strength and durability.

Designed for Bar Pushers/Barfeeders

Fixed-length Klamp collet chucks are designed to work with bar loaders and bar feeders by not interfering with the process of the bar feeder action.



Long Series Power Collet Chuck for Bar Machining

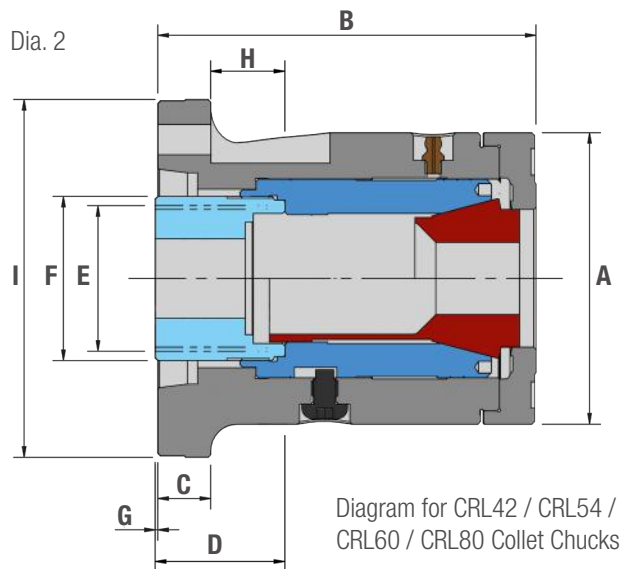
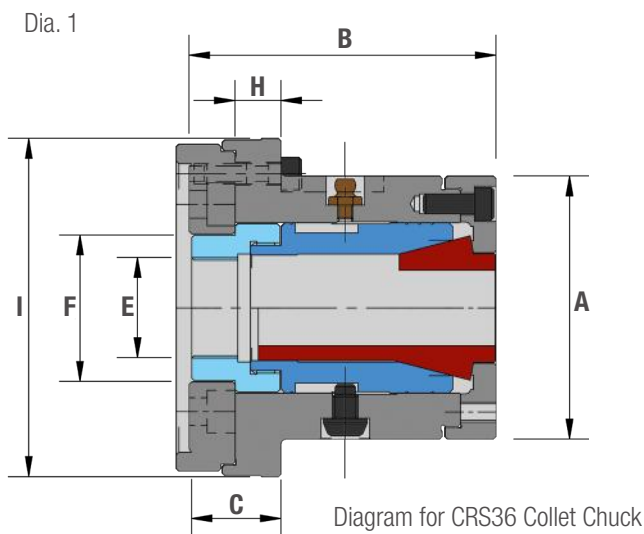

KLAMP Type		CRS36	CRL42		CRL54	CRL60			CRL80		
Mounting		Z115	Z140	A5	A6	A6	Z170	A6	A8	Z220	A8
Part Number		CRS36	CRL42	CRL42A5	CRL42A6	CRL54A6	CRL60	CRL60A6	CRL60A8	CRL80	CRL80A8
Spring Collet Type		D171E	D173E		D853	D185E			D193E		
Spring Collet Gripping Range *	Minimum	1.6	2		2	3			12		
	Maximum	36	42		54	60			80		
Spring Collet Increments		0.5	0.5		0.5	0.5			0.5		
Varibore Collet Type		D671	D673		D120	D677			D660		
Varibore Collet Gripping range**	Minimum	4	4		4	4			12		
	Maximum	36	42		53.9	60			80		
Varibore Collet Increments		2	2		3	2			3		
Rubberflex Collet Type		-	DRFC673		-	DRFC677			-		
Rubberflex Collet Gripping Range***	Minimum	-	7*		-	19*			-		
	Maximum	-	43*		-	65*			-		
Rubberflex Collet Increments		-	2		-	2			-		
A		105	110		138	138			190		
B		125	128	143	145	166	143	160	156	170	176
C		18	20	20	30	27	24	27	36	19	25
D		35	49		48	48			63		
E Maximum		M50 x 1.5	M55 x 1.5		M70 x 1.5	M70 x 1.5			M90 x 2.0		
F		58	62		80	80			100		
G Maximum		-1	16	1	-1	-2	15	-2	2	48	42
G Minimum		-8	9	-6	-8	-12	8	-9	-5	36	30
H		18	18	28	19	23	14	23	9	13	13
I		135	160	135	165	165	190	165	210	230	220
Sleeve stroke		7	7		10	7			12		
Max. input force	kN	18	25		30	30			45		
Max. Gripping Force	kN	36	55		60	60			78		
Max. Speed	min ⁻¹	7000	7100		6300	6300			4500		
Net Weight	kg	8	9	9.5	11	16	15.2	16	19	30	30
Matching Kitagawa Cylinders		S1036	S1246		S1552	S1552/S1875			S2091		

* See pages 14-18 for more Spring Collet information.

** See pages 22-23 for more Varibore Collet information.

*** DRFC673 Rubber-flex collets are only suitable for the CRL42 Collet chuck and are available in smooth and full grip versions (smooth version is only available for 11mm diameters and smaller). DRFC677 Rubber-flex collets are only suitable for the CRL60 Collet chuck and are available in smooth and full grip versions (smooth version is only available for 61mm diameters and larger). See pages 24-25 for more information.

Spring Collets for CRL80 and QCRL80 Collet Chucks

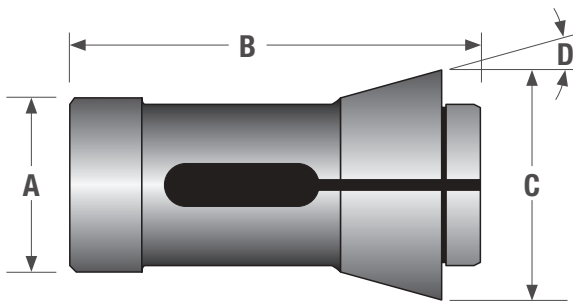

D193E Spring Collets

- DIN 6343 Type: H-47
- Round standard shape only
- Specify which gripping surface you require – Annular Serrations or Smooth
- 0.5mm sizes and other shapes available upon request

Dimensions (Metric)

A	B	C	D
90	130	107	15°

Gripping Diameter	Round
12mm	D193E R12
13mm	D193E R13
14mm	D193E R14
15mm	D193E R15
16mm	D193E R16
17mm	D193E R17
18mm	D193E R18
19mm	D193E R19
20mm	D193E R20
21mm	D193E R21
22mm	D193E R22
23mm	D193E R23
24mm	D193E R24
25mm	D193E R25
26mm	D193E R26
27mm	D193E R27
28mm	D193E R28
29mm	D193E R29
30mm	D193E R30
31mm	D193E R31
32mm	D193E R32
33mm	D193E R33
34mm	D193E R34
35mm	D193E R35
36mm	D193E R36
37mm	D193E R37
38mm	D193E R38
39mm	D193E R39
40mm	D193E R40
41mm	D193E R41
42mm	D193E R42
43mm	D193E R43
44mm	D193E R44
45mm	D193E R45
46mm	D193E R46

Gripping Diameter	Round
47mm	D193E R47
48mm	D193E R48
49mm	D193E R49
50mm	D193E R50
51mm	D193E R51
52mm	D193E R52
53mm	D193E R53
54mm	D193E R54
55mm	D193E R55
56mm	D193E R56
57mm	D193E R57
58mm	D193E R58
59mm	D193E R59
60mm	D193E R60
61mm	D193E R61
62mm	D193E R62
63mm	D193E R63
64mm	D193E R64
65mm	D193E R65
66mm	D193E R66
67mm	D193E R67
68mm	D193E R68
69mm	D193E R69
70mm	D193E R70
71mm	D193E R71
72mm	D193E R72
73mm	D193E R73
74mm	D193E R74
75mm	D193E R75
76mm	D193E R76
77mm	D193E R77
78mm	D193E R78
79mm	D193E R79
80mm	D193E R80

Emergency Collet with soft face and pilot hole 10mm dia. is available - Part No. **D193E-EMERGENCY**

Varibore Collets for CRS36, CRL42, QCRL42, CRL60, QCRL60, CRL80 & QCRL80 Collet Chucks

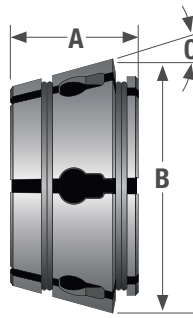

Varibore Collets - Type: DIN 6343

- Round, Hexagon or Square
- Specify which gripping surface you require – Supergrip Serrations (Heavy duty), Annular serrations or Smooth
- Other shapes available upon request

Dimensions (Metric)

Part No.	A	B	C
D671	38	56.5	14.75°
D673	39	61.5	14.75°
D677	45	85.5	14.75°
D660	48	1087.5	14.75°

Gripping Range mm	D671 DIN for CRS36			D673 DIN for CRL42 & QCRL42			D677 DIN for CRL60 & QCRL60			D660 DIN for CRL80 & QCRL80	
	Round	Hexagon	Square	Round	Hexagon	Square	Round	Hexagon	Square	Round	Hexagon
4 - 6	D671-R06	D671-X06	D671-S06	D673-R06	D673-X06	D673-S06	-	-	-	-	-
6 - 8	D671-R08	D671-X08	D671-S08	D673-R08	D673-X08	D673-S08	D677-R08	D677-X08	D677-S08	-	-
8 - 10	D671-R10	D671-X10	D671-S10	D673-R10	D673-X10	D673-S10	D677-R10	D677-X10	D677-S10	-	-
10 - 12	D671-R12	D671-X12	D671-S12	D673-R12	D673-X12	D673-S12	D677-R12	D677-X12	D677-S12	-	-
12 - 14	D671-R14	D671-X14	D671-S14	D673-R14	D673-X14	D673-S14	D677-R14	D677-X14	D677-S14	D660-R14	D660-X14
14 - 16	D671-R16	D671-X16	D671-S16	D673-R16	D673-X16	D673-S16	D677-R16	D677-X16	D677-S16	D660-R16	D660-X16
16 - 18	D671-R18	D671-X18	D671-S18	D673-R18	D673-X18	D673-S18	D677-R18	D677-X18	D677-S18	D660-R18	D660-X18
18 - 20	D671-R20	D671-X20	D671-S20	D673-R20	D673-X20	D673-S20	D677-R20	D677-X20	D677-S20	D660-R20	D660-X20
20 - 22	D671-R22	D671-X22	D671-S22	D673-R22	D673-X22	D673-S22	D677-R22	D677-X22	D677-S22	D660-R22	D660-X22
22 - 24	D671-R24	D671-X24	D671-S24	D673-R24	D673-X24	D673-S24	D677-R24	D677-X24	D677-S24	D660-R24	D660-X24
24 - 26	D671-R26	D671-X26	-	D673-R26	D673-X26	D673-S26	D677-R26	D677-X26	D677-S26	D660-R26	D660-X26
26 - 28	D671-R28	D671-X28	-	D673-R28	D673-X28	D673-S28	D677-R28	D677-X28	D677-S28	D660-R28	D660-X28
28 - 30	D671-R30	-	-	D673-R30	D673-X30	D673-S30	D677-R30	D677-X30	D677-S30	D660-R30	D660-X30
30 - 32	D671-R32	-	-	D673-R32	D673-X32	-	D677-R32	D677-X32	D677-S32	D660-R32	D660-X32
32 - 34	D671-R34	-	-	D673-R34	D673-X34	-	D677-R34	D677-X34	D677-S34	D660-R34	D660-X34
34 - 36	D671-R36	-	-	D673-R36	D673-X36	-	D677-R36	D677-X36	D677-S36	D660-R36	D660-X36
36 - 38	-	-	-	D673-R38	-	-	D677-R38	D677-X38	D677-S38	D660-R38	D660-X38
38 - 40	-	-	-	D673-R40	-	-	D677-R40	D677-X40	D677-S40	D660-R40	D660-X40
40 - 42	-	-	-	D673-R42	-	-	D677-R42	D677-X42	D677-S42	D660-R42	D660-X42
42 - 44	-	-	-	-	-	-	D677-R44	D677-X44	-	D660-R44	D660-X44
44 - 46	-	-	-	-	-	-	D677-R46	D677-X46	-	D660-R46	D660-X46
46 - 48	-	-	-	-	-	-	D677-R48	D677-X48	-	D660-R48	D660-X48
48 - 50	-	-	-	-	-	-	D677-R50	D677-X50	-	D660-R50	D660-X50
50 - 52	-	-	-	-	-	-	D677-R52	D677-X52	-	D660-R52	D660-X52
52 - 54	-	-	-	-	-	-	D677-R54	-	-	D660-R54	D660-X54
54 - 56	-	-	-	-	-	-	D677-R56	-	-	D660-R56	D660-X56
56 - 58	-	-	-	-	-	-	D677-R58	-	-	D660-R58	D660-X58
58 - 60	-	-	-	-	-	-	D677-R60	-	-	D660-R60	D660-X60
60 - 62	-	-	-	-	-	-	-	-	-	D660-R62	D660-X62
62 - 64	-	-	-	-	-	-	-	-	-	D660-R64	D660-X64
64 - 66	-	-	-	-	-	-	-	-	-	D660-R66	D660-X66
66 - 68	-	-	-	-	-	-	-	-	-	D660-R68	D660-X68
68 - 70	-	-	-	-	-	-	-	-	-	D660-R70	-
70 - 72	-	-	-	-	-	-	-	-	-	D660-R72	-
72 - 74	-	-	-	-	-	-	-	-	-	D660-R74	-
74 - 76	-	-	-	-	-	-	-	-	-	D660-R76	-
76 - 78	-	-	-	-	-	-	-	-	-	D660-R78	-
78 - 80	-	-	-	-	-	-	-	-	-	D660-R80	-

Emergency Collets with soft face and pilot hole is available for all types

QC & C Series Standard Accessories

Work Stops

- Stops can be provided to allow for accurate z-axis positioning of short workpieces within the collet chuck.
- A threaded stud is provided for easy adjustment to suit your work piece
- All stops are easily installed from the front face utilising a side bolt to hold the stop securely in place.
- These stops can be installed on all QC & C series collet chucks.
- Full length spindle stops can also be provided for long work pieces, these can utilise the entire length of your machine spindle, please contact your Klamp supplier to see the maximum length stop your machine could accommodate.

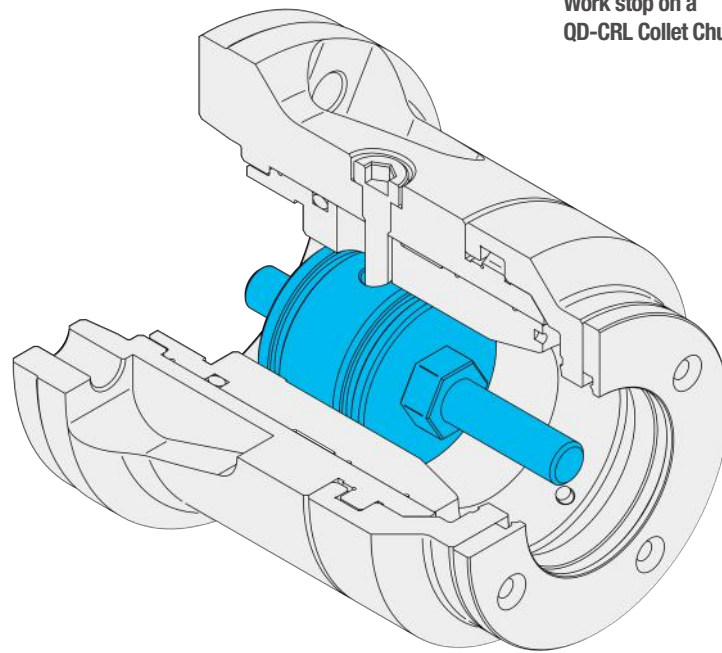

Work stop on a QD-CRL Collet Chuck

Spring Ejectors

- Standard spring ejectors for QC & C series are used for second-spindle operations to expel finished workpieces into the parts catcher.
- Many variants of spring ejector are available to suit your production process.
- Spring ejectors can be installed on all QC & C series collet chucks.
- Full length hydraulic or pneumatic ejectors can also be provided for long work pieces, this can utilise the entire length of your machine spindle, please contact your Klamp supplier to see the maximum length stop your machine could accommodate.

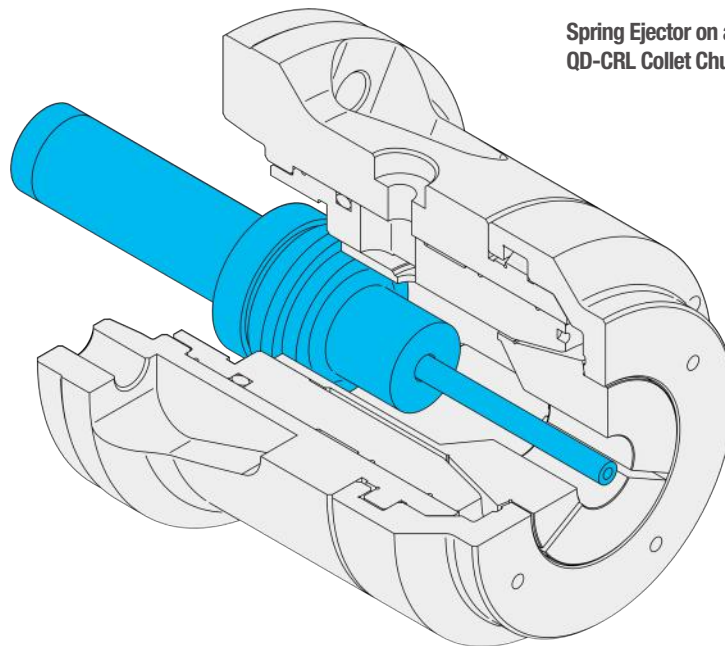

Spring Ejector on a QD-CRL Collet Chuck